

ECE 210 Final Project

Snake on a NeoPixel 8x8 LED Matrix

Overview

- Implemented Snake on an 8x8 WS2812B NeoPixel LED Matrix
- Controlled by the Arduino Uno (ATmega328P)
- Input (turn left, turn right) via 2 push-buttons connected to D2 and D3 and going to GND
- Power obtained via USB connection to Laptop or any external voltage source

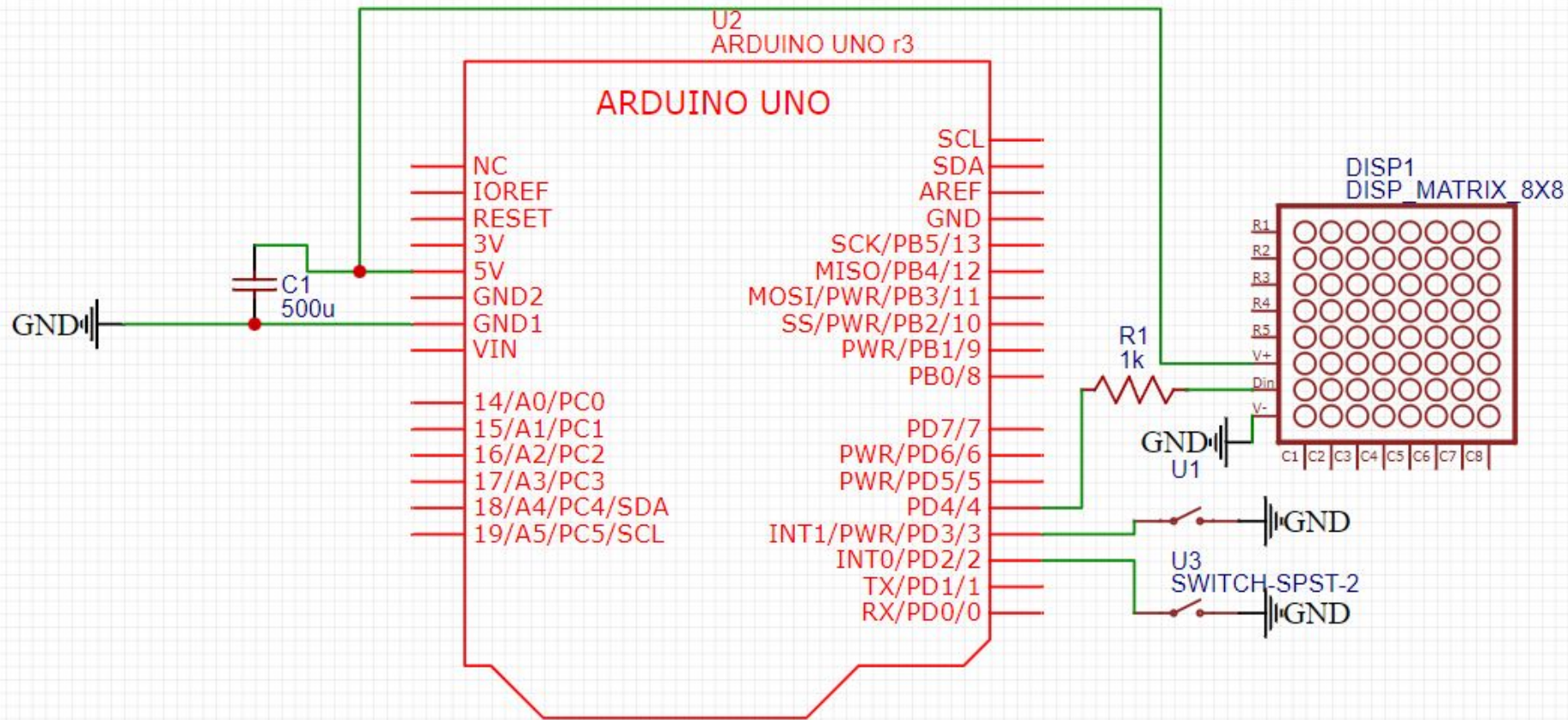

Code Flowchart + Adafruit Arduino Library

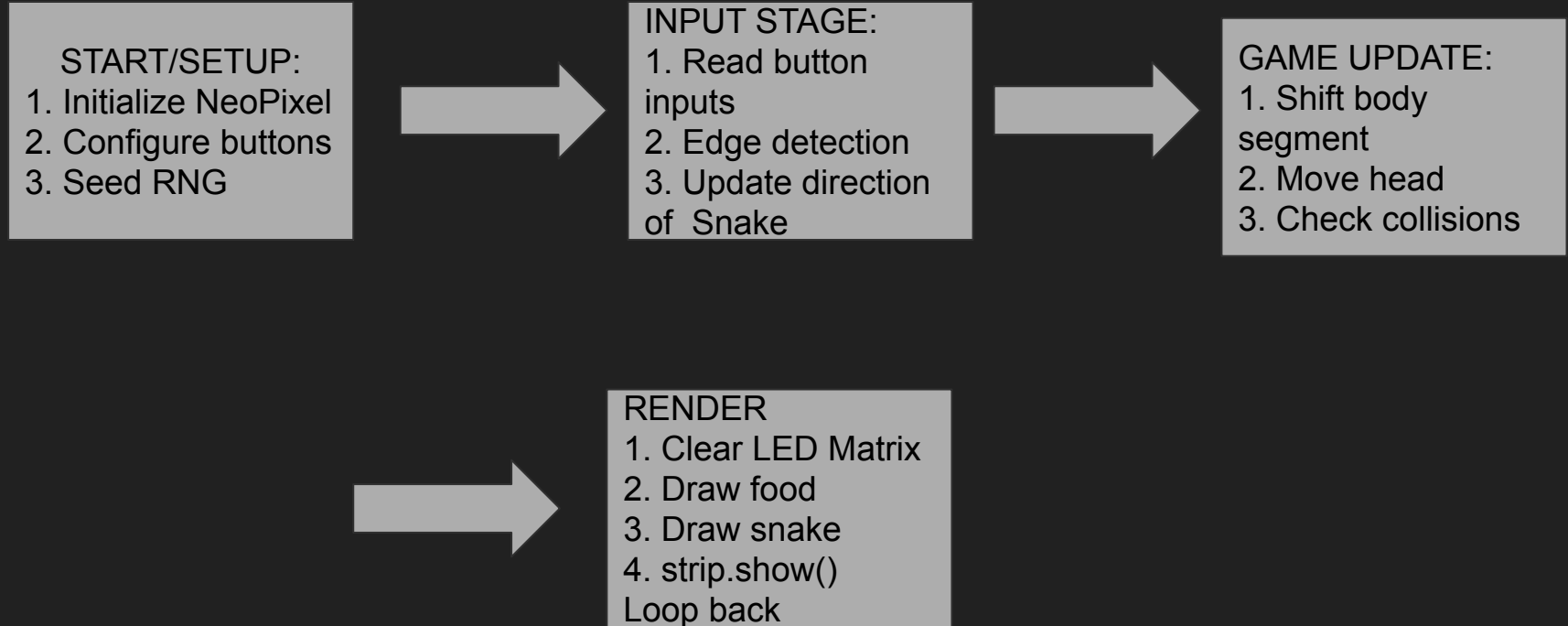

Demo!

